

# Solving the Bottleneck in the Hybrid MIMO Transceiver Scheme: Channel Coding vs. Partial CSI at Transmitter Side

W. C. Freitas Jr., F. R. P. Cavalcanti and R. R. Lopes

**Resumo**—Neste paper, nós tentamos resolver o “gargalo” presente nos esquemas de transceptores MIMO híbridos propondo e comparando algumas possíveis soluções. Em [1], nós avaliamos o desempenho dos esquemas de transceptores MIMO híbridos considerando um esquema de codificação de canal nas camadas seguindo a técnica V-BLAST. Nós aqui propomos um novo esquema usando a informação parcial do estado atual do canal (CSI, da sigla em Inglês) no lado do transmissor e comparamos o desempenho com a solução considerando a codificação de canal.

**Palavras-Chave**—MIMO, codificação de canal, diversidade e multiplexação

**Abstract**—In this paper, we try to solve the bottleneck present in the hybrid MIMO transceiver schemes proposing and comparing some possible solutions. In [1], we evaluate the performance of the hybrid MIMO transceiver schemes considering a channel coding scheme in the layers following the V-BLAST approach. We here propose a new scheme using a partial Channel State Information (CSI) at the transmitter side and compare the performance with the solution regarding the channel coding scheme.

**Keywords**—MIMO, channel coding, diversity and multiplexing

## I. INTRODUCTION

The use of the multiple antennas has proliferated now in the wireless system as a possible solution to the capacity limitation of the current wireless systems. With the use of multiple antennas over certain scenarios we can achieve an increase in the capacity almost linear with the number of antennas. The idea is that the use of multiple antennas create a Multiple-Input Multiple-Output (MIMO) linear system in which the MIMO channel linking the transmitter and receiver antennas can be seen as multiple single-antenna subchannels with no additional power consumption, time transmission and bandwidth. These multiple subchannels can be separated through their spatial signatures in a environment rich in multipaths. Another well-known advantage of multiple antennas is the providing of spatial diversity through the multiple links created by the multiple antennas. The idea is that with multiple links there exists a lower probability that all of them experiment a deep fading situation.

W. C. Freitas Jr and F. R. P. Cavalcanti, Teleinformatic Engineering Department, Federal University of Ceará, Fortaleza, Brazil, E-mails: ext-walter.freitas@nokia.com, rodrigo@gtel.ufc.br. R. R. Lopes, Communications Department, State University of Campinas, Campinas, Brazil, E-mail: rlopes@decom.fee.unicamp.br. R. R. Lopes is supported by Fundação de Amparo à Pesquisa do Estado de SP (FAPESP), grant no. 03/07814-1.

In [2] it was shown that in fact exists a tradeoff in the MIMO wireless channel. Zheng and Tse have shown that when one tries to maximize one possible gain of the MIMO wireless channels leads to a degradation of the other gain. For example, Space-Time Block Codes (STBC) well-known schemes in providing diversity gain have no concerns about the capacity gain. On the other hand, Vertical Bell Laboratories Layered Space-Time (V-BLAST) schemes were designed aiming multiplexing as many different symbols as possible.

Zheng and Tse just characterized the tradeoff not proposing any scheme capable of achieving it. A solution in this direction was proposed with a modification in the V-BLAST scheme, called Diagonal BLAST [3], in which the transmitted symbols are multiplexed in all the transmit antennas available, but in different time instants. Unfortunately, this solution brings a considerable delay in order to achieve a diversity gain, and thus is not very practical.

Hybrid MIMO Transmission Schemes (HMTS) arise as a solution to jointly achieve spatial multiplexing and diversity gains. With HMTS, it is possible to considerably increase the data rate while keeping a satisfactory link quality in terms of Bit Error Rate (BER) or Block Error Rate (BLER). In fact, HMTS apply pure diversity schemes (e.g. STBC) jointly with pure spatial multiplexing schemes (e.g. V-BLAST): parts of the data are space-time coded across some antennas, and these parts are combined in layers, using a V-BLAST approach. As spatially-multiplexed layers see each other as interference, Interference Cancellation (IC) similar to that employed in V-BLAST is mandatory in the receiver. Otherwise, since the V-BLAST layers transmit with no protection, these layer limits the performance of the whole receiver.

In fact, due to the designed of the HMTS in which are disposed in a parallel way spatial diversity branches (through the STBC) and spatial multiplexing branches (through the V-BLAST) to achieve diversity and multiplexing gain at the same time, the spatial multiplexing branches are the bottleneck in the performance. The reason for that is due to the spatial multiplexing branches are transmitted with no protection, thus, being more susceptible to the fading effect. We can realize this bottleneck looking at Fig. 4 which shows the comparison between the two branches (diversity and multiplexing) of the HMTS called G3+1. By this result we can see the huge difference in the performance of the spatial diversity branch (layer 1 - STBC) and the spatial multiplexing branch (layer 2 - VBLAST). In this article we will present solutions to the bottleneck present in the Hybrid Transceiver MIMO

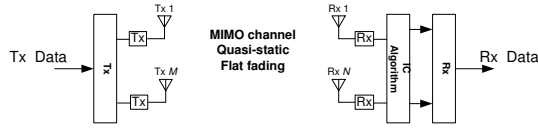

Fig. 1. MIMO schemes general structure.

schemes. We propose two possible solutions: one regarding channel coding in the VBLAST layer of the HMTS and other proposing a partial Channel State Information (CSI) at the transmitter side, aiming to do a more clever allocation for the VBLAST subchannel.

This article is organized as follow. In section II, we present the MIMO system and channel model considered. In Section III we review conventional MIMO transceiver schemes, while in Section IV we propose the Hybrid MIMO Transceiver Schemes (HMTS). Section V presents performance results. In Section VI we state some conclusions and anticipate future work.

## II. SYSTEM AND CHANNEL MODELS

In this paper, we consider a transmitter equipped with an  $M$ -element antenna and a receiver equipped with an  $N$ -element antenna array, as seen in Fig. 1. The transmitted signals are assumed to go through a random channel matrix  $H$ , where the elements of  $H$  are random variables. The quasi-static block fading model is assumed; in other words, the channel matrix  $H$  is randomly generated, but remains constant during the transmission of one space-time code word of length  $T$ . A new random channel matrix, independent of the previous one, is then generated for each new space-time code word. Plus, we assume i.i.d circularly symmetric Gaussian noise samples. For all the MIMO transmission schemes, we assume that the total transmit power is fixed (normalized to 1) and equally divided across the transmit antennas. Ideal symbol timing is assumed at the receiver. Thus, we can relate the transmit and receiver symbols through the relation in complex baseband and the symbol rate

$$x = \sqrt{\frac{\rho}{M}} Hs + v, \quad (1)$$

where  $x \in \mathcal{C}^N$  denotes the vector of complex received symbols during any given channel use,  $s \in \mathcal{C}^M$  denotes the vector of the complex transmitted symbols,  $H \in \mathcal{C}^{N \times M}$  denotes the channel matrix,  $v \in \mathcal{C}^N$  is the zero-mean, unit variance and complex-Gaussian distributed noise that is spatially and temporally white, and  $\rho$  is the Signal-to-Noise Ratio (SNR). The entries of channel matrix  $H$  and the transmitted vector  $s$  are assumed to have unit variance, implying that

$$E[\text{tr}(HH^H)] = MN, \quad (2)$$

and

$$E[\text{tr}(s^H s)] = M, \quad (3)$$

where  $\text{tr}(\cdot)$  denotes the trace of the matrix represented by  $(\cdot)$ . The normalization factor  $\sqrt{\frac{\rho}{M}}$  in (1) guarantees that the SNR at each receiver antenna is independent of  $M$ .

## III. CONVENTIONAL MIMO TRANSCIVER SCHEMES

In general, MIMO architectures can be classified in one of three groups depending on the provided gains: Pure Diversity Schemes, Pure Multiplexing Schemes and the new Hybrid MIMO Schemes. Heretofore, we denote the Pure Diversity Schemes and Pure Multiplexing Schemes as conventional MIMO transceiver schemes. As their names imply, conventional MIMO transmission structures provide either *diversity gain* or *spatial multiplexing gain*, but not both. In the following, we briefly describe the conventional MIMO Transceivers Schemes.

### A. Pure Diversity Schemes

Space-Time Codes (STC) [4] are a well-known technique that provides diversity gain. Space-Time Codes use channel coding techniques combined with multiple transmit antennas, introducing temporal and spatial correlations into signals transmitted from different antennas, thus increasing the diversity order at the receiver. Two techniques widely used for STC are Space-Time Block Codes (STBC) and Space-Time Trellis Codes (STTC). In the latter, when the number of antennas is fixed, the decoding complexity (measured by the number of trellis states at the decoder) increases exponentially as a function of the diversity level and modulation order. In addressing the issue of decoding complexity, Alamouti [5] discovered a remarkable STBC scheme, denoted here as G2, for transmission with two antennas in quasi-static and flat fading channels. Due to its very simple encoding and decoding, Alamouti's scheme is being considered for the Universal Mobile Telecommunications System (UMTS) standards [6].

The success of G2 spurred a search for new schemes of different rates and for more transmit antennas. We now describe some of these STBC schemes [4], [5], which will be considered in this article. We will follow the notation presented in [4] in which Tarokh et al. named their schemes for  $M > 2$  as:

- the letter G represents schemes achieving the rate of 1/2;
- the letter H represents schemes achieving the rate of 3/4;
- Following the letters (G or H) is the number of transmit antennas of the schemes.

For example, H3 is a scheme with rate 3/4 designed for 3 transmit antennas, while G4 is a scheme with rate 1/2 designed for 4 transmit antennas.

1) *G3 STBC Scheme*: In this scheme the transmitted signals can be organized in the equivalent space-time coding matrix

$$S_{G3[k, k+1, k+2, k+3]} = \begin{bmatrix} s_1 & s_2 & s_3 \\ -s_2 & s_1 & -s_4 \\ -s_3 & s_4 & -s_1 \\ -s_4 & -s_3 & s_2 \\ s_1^* & s_2^* & s_3^* \\ -s_2^* & s_1^* & -s_4^* \\ -s_3^* & s_4^* & s_1^* \\ -s_4^* & -s_3^* & s_2^* \end{bmatrix}^T, \quad (4)$$

where the spatial dimension varies column-wise and the temporal dimension row-wise. Due to the orthogonality of

the transmit matrix  $S_{G3}[k, k+1, k+2, k+3]$ , a simple linear operation in the receiver can be used to detect the transmit symbols  $s_1, s_2, s_3$  and  $s_4$ . However, in this case, the channels need to be quasi-static during eight consecutive symbol periods,  $[k], \dots, [k+7]$ . Since the G3 scheme multiplexes  $n_s = 4$  information symbols ( $s_1, s_2, s_3$  and  $s_4$ ) in  $n_t = 8$  consecutive channel realizations, the effective spectral efficiency of this scheme is equal to  $(n_s/n_t) \cdot \log_2 \mathcal{M} = (1/2) \cdot \log_2 \mathcal{M}$  bps/Hz. Schemes that achieve  $n_s/n_t = 1$  are also known as Full Rate (FR) schemes.

### B. Pure Multiplexing Scheme

Another approach for multiple-antenna transmission is to focus on the maximization of the spectral efficiency. Well-known schemes proposed with this focus are the Bell Laboratories Layered Space-Time (BLAST) schemes, such as the Vertical-BLAST and Diagonal-BLAST [3]. In the V-BLAST scheme, all the antennas are used to multiplex different symbols in each symbol period. In this scheme each different multiplexed symbol is defined as a layer. For instance, in the case of three transmit antennas we have three layers. The transmitted signals at time instant  $[k]$ , considering three transmit antennas, can be organized in the equivalent space-time coding matrix

$$S_{V-BLAST}[k] = \begin{bmatrix} s_1 & s_2 & s_3 \end{bmatrix}^T. \quad (5)$$

As spatially-multiplexed symbols cause interference in each other, signal processing is mandatory at the receiver in order to cancel interference.

The operation of mitigating the interference with linear signal processing is normally referred to as nulling, two possible solutions are Zero Forcing (ZF) and Minimum Mean Square Error (MMSE). However, a superior performance can be reached when a non-linear spatial-processing approach is used. A common non-linear detector is based on interference cancellation (IC): the impact from detected bits on the received signal is reconstructed and subtracted. Assuming correct decisions, the resulting signal is free from the interference of the detected symbols, yielding better estimates of the remaining symbols. Regarding non-linear IC algorithms we can highlight the approach based in a successive way. In the Successive Interference Cancellation (SIC) scheme the IC is performed successively for one layer at time, while for the parallel approach the IC is done in parallel for all layers at once. The advantage of this approach is the low delay since the cancellation is parallel, however, it is not as robust as the SIC.

## IV. HYBRID MIMO TRANSCEIVER SCHEMES (HMTS)

As mentioned in the introduction, the use of multiple transmit and receive antennas may result in great capacity gains. Indeed, in a rich scattering environment the deployment of antenna arrays at both links-ends results in a capacity that increases almost linearly with the minimum number of antennas [3], [7]. Such a capacity increase is denoted spatial multiplexing gain. MIMO antenna systems may also provide

diversity gain, which is a measure of robustness against fading [4].

Essentially, the research in the multiple antenna transmission schemes has been divided in two main branches. Information theory studies view multiple antennas as the source of multiple degrees of freedom, over which different streams may be transmitted. This results in significant gains in terms of the channel capacity at high SNR. On the other hand, the space-time code designers use multiple antennas to achieve diversity gains, which leads to a lower probability of detection error at low SNR. There is, however, a tradeoff: the diversity gain can only be increased if the multiplexing gain is sacrificed [2]. As a feasible realization structure for the tradeoff in the MIMO channel arises the Hybrid MIMO Transceiver Schemes.

In general, the transmission process of a hybrid scheme can be divided in layers, extending the definition of a layer in the V-BLAST case. In the hybrid case, a layer consists of the streams of symbols at the output of a STBC, which are sent to a group of antennas, or to an uncoded stream, which is transmitted from a single antenna. Based on this concept of layers, hybrid MIMO transceiver schemes combine pure diversity schemes (e.g. Space-Time Block Codes (STBC)) with pure spatial multiplexing schemes (e.g. Vertical Bell Laboratories Layered Space Time (V-BLAST)). In hybrid systems, some layers are space-time coded across two, three or four antennas. For the remaining layers, a V-BLAST approach is used. With this idea, hybrid MIMO schemes achieve a compromise between spatial multiplexing and transmit diversity gains. In the remainder of this section we present some specific hybrid MIMO schemes. The notation considered is, the space-time coded layers follow the denomination of the STBC regarded (e.g. G2 or G3), while each uncoded streams following the V-BLAST scheme is denoted in the label of HMTS as (1). For example, the system designed to four transmit antennas consisting of two layers, one space-time coded through the G3 scheme and other uncoded layer following the VBLAST scheme, is denoted as G3+1.

### A. HMTS Designed for 4 Transmit Antennas

#### • G3+1

Figures 2 and 3 depict the HMTS considered in this work, they show the transmitter and receiver, respectively. The four transmit antennas are now divided into two multiplexing layers, where the first one groups three antenna signals that are space-time coded using G3 code [4]. The equivalent space-time coding matrix for this hybrid scheme is given by

$$S_{G3+1}[k, \dots, k+7] = \begin{bmatrix} s_1 & s_2 & s_3 & s_5 \\ -s_2 & s_1 & -s_4 & s_6 \\ -s_3 & s_4 & s_1 & s_7 \\ -s_4 & -s_3 & s_2 & s_8 \\ s_1^* & s_2^* & s_3^* & s_9 \\ -s_2^* & s_1^* & -s_4^* & s_{10} \\ -s_3^* & s_4^* & s_1^* & s_{11} \\ -s_4^* & -s_3^* & s_2^* & s_{12} \end{bmatrix}^T. \quad (6)$$

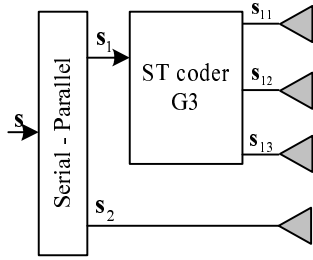

Fig. 2. Architecture of the HMTS G3+1 transmitter

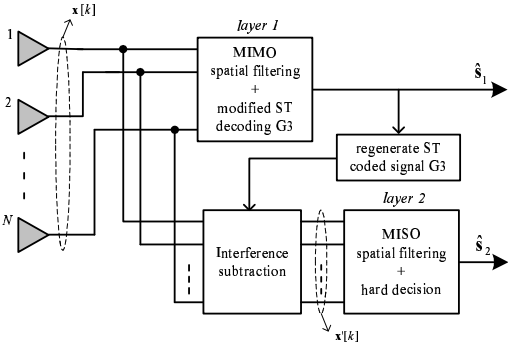

Fig. 3. Architecture of the HMTS G3+1 receiver, considering modified SIC as IC algorithm.

From (6), we observe that  $n_s = 12$  information symbols (four from the first layer and eight from the second one) are transmitted in  $n_t = 8$  consecutive channel realizations. Thus, the effective spectral efficiency of this scheme is equal to  $(n_s/n_t) \cdot \log_2 \mathcal{M} = 1.5 \cdot \log_2 \mathcal{M}$  bps/Hz. This represent three times the spectral efficiency of G3.

### B. Modified Interference Cancellation Algorithm for the Hybrid MIMO Transceiver Schemes

As the proposed HMTS have at least two layers, at least one of which is space-time block coded. Further, they all employ orthogonal STC, whose detection involves simple linear operations in the receiver. We now propose a receiver for the HMTS that combines the simplicity of Successive Interference Cancellation (SIC) algorithm with the simplicity of decoding of orthogonal STC. In fact, we adapt the IC algorithm in such a way that the orthogonal structure of the space-time code is preserved as much as possible in its output signal. The general structure of the receiver is shown in Fig. 3. We will explain this structure for the G3+1 case. The extension to other hybrid schemes is straightforward.

In the case of G3+1, we have two layers: a standard G3 space-time block code at the first layer and a non-space-time-coded layer. In this case, the error vector at the output of the MIMO-MMSE spatial filter is given by

$$e[k] = Wx[k] - H_d s_1[k] = Wx[k] - x_d[k], \quad (7)$$

where  $x_d[k] = H_d s_1[k]$  is now the desired space-time coded signal associated to the first multiplexing layer. In

Fig. 3 the MIMO spatial filter mitigates the interference from other layers, so that its output signal consists of a single space-time-coded signal or of a single uncoded stream.

Contrarily to the classical MIMO-MMSE spatial filter, where the desired signal is  $s_d[k]$ , here the desired signal consists of the original transmitted signal modified by desired MIMO channel response  $H_d$ , which can be interpreted as the “virtual” channel between the transmitter and the output of the spatial filter.

The MSE cost function may be written as

$$J_{MMSE} = E\{\|Wx[k] - x_d[k]\|^2\}. \quad (8)$$

The optimal coefficients are found by minimizing the above cost function with respect to  $W$ . The solution is given by

$$W = R_{x_d x} R_{x x}^{-1}, \quad (9)$$

where  $R_{x x} = E\{x[k]x^H[k]\}$  and  $R_{x_d x} = E\{x_d[k]x^H[k]\}$  are the input covariance matrix and a cross-correlation matrix, respectively.

Figure 3 shows the architecture of the SIC receivers for the HMTS G3+1. Clearly, we can see in these figures that the layers are processed successively, in a two stage process in which

- 1) first a nulling of the interference from the undetected layers is made;
- 2) then, the layer goes through a decoder for the STBC used in this layer;
- 3) finally, the received space-time coded signal corresponding to this layer is regenerated and its impact is cancelled from the received signal.

## V. PERFORMANCE RESULTS

This section presents simulation results that compare two possible solutions for the problem of uncoded layers for the hybrid MIMO transceiver schemes. We present the performance of the proposed solutions in terms of BER. The performance of the HMTS is evaluated here by means of numerical results from Monte-Carlo simulations. The curves are plotted against the average  $E_b/N_0$  per receive antenna. Perfect channel estimation is assumed<sup>1</sup>. Unless otherwise noted, all schemes employ binary-phase shift-keying (BPSK) modulation. We assume a MIMO system with 3 transmit and 3 receive antennas.

### A. The Problem of Uncoded Layers for the Hybrid MIMO Transceiver Schemes

As defined before, the HMTS regards multiplexing layers in which some layers are space-time coded through the STBC and other layers are just transmitted following the VBLAST approach with no coding. Since the layers following the VBLAST idea transmit with no protection, this layer is the bottleneck in the whole receiver performance. We can confirm this affirmation, seeing the Figures 4, in which the layer 1 (STBC G3) presents an excellent result in terms of BER,

<sup>1</sup>The degradation due to imperfect channel estimation is negligible if the number of transmit antennas is small [8], [9], as is the present case.

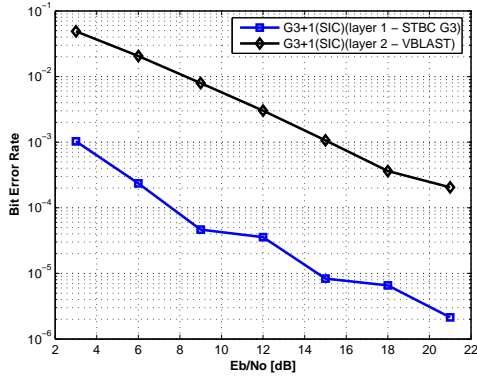

Fig. 4. Comparison of BER performance for the layers of the HMTS G3+1.

while the layer 2 (VBLAST) has a huge difference in the performance.

In [1] we proposed a solution for this bottleneck; considering a convolutional code in the layers following the VBLAST approach, considering in the receiver Hard and Soft output Viterbi algorithms. In this work we aim to compare this solution with a new solution in which the transmitter has some knowledge of the CSI and makes a clever layer allocation, in such a way that the better channel is allocated for the VBLAST scheme, since this is the bottleneck in the performance. Following we describe in more details both proposed solutions.

1) *Channel Coding Approach*: channel coding is a well-known strategy to provide protection in a communication link. A very successful channel coding scheme is the convolutional code. In this scheme the protection (redundancy symbols) take not only the actual input symbol but also the past input symbols. Thus, essentially the convolutional code can be seen as a state machine where each state are the actual state of the memory of the encoder. A well-known technique to decoder this kind of channel coding is the Viterbi Algorithm (VA).

In our approach we consider the rate-1/2 memory-2 Recursive Systematic Convolutional (RSC) code that is defined by the generator (1,5/7) in octal form. As the decoding algorithm we consider two approaches: Hard Output Viterbi Algorithm (HOVA) and Soft Output Viterbi Algorithm (SOVA). In the SOVA procedure, the trellis computations are done in two directions: a forward and a backward one. The first part of the algorithm, trellis is run in the forward direction and SOVA behaves like a traditional Viterbi Algorithm (VA). In the second part, the trellis is run in the backward direction. In this part, the metric for each state are stored by the algorithm and soft-output information of bits is computed as a Likelihood Ratio (LLR) in the form described below

$$\Lambda(s_i) \triangleq \log \left( \frac{P\{s_i = 1|\mathbf{x}\}}{P\{s_i = 0|\mathbf{x}\}} \right). \quad (10)$$

where  $s_i$  is the transmitted codeword and  $\mathbf{x}$  is the received sequence.

In Figure 5, we present the result regarding the channel coding solution. We can see that the SOVA is the better

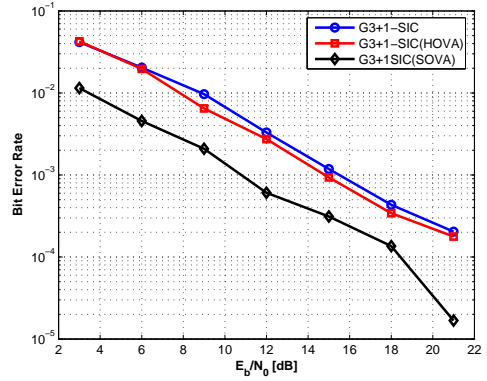

Fig. 5. Result for the first possible solution: channel coding.

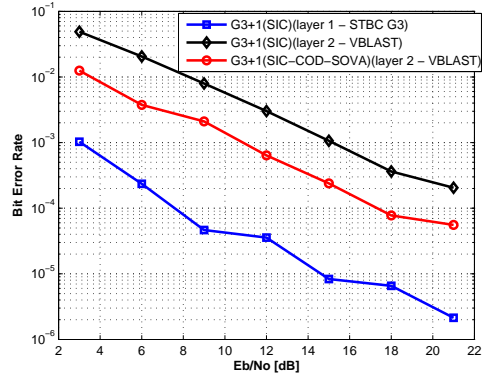

Fig. 6. Result per layer for the first possible solution: channel coding.

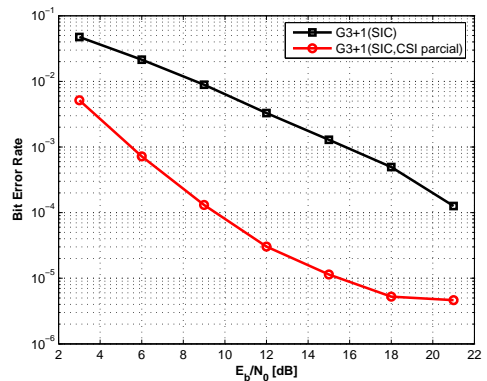

Fig. 7. Result for the second possible solution: partial CSI at transmitter side.

solution, for example, in a BER value of  $10^{-3}$  the SOVA achieve a gain of 6 dB compared to the pure SIC. Figure 6 show the obtained results for the layer 2 considering the channel coding. As a benchmark result we consider the BER for the layer more protected, layer 1 (STBC G3). By the results we can see that a gain is obtained, but still remains a huge difference in the BER performance between the layer 1 and the layer 2.

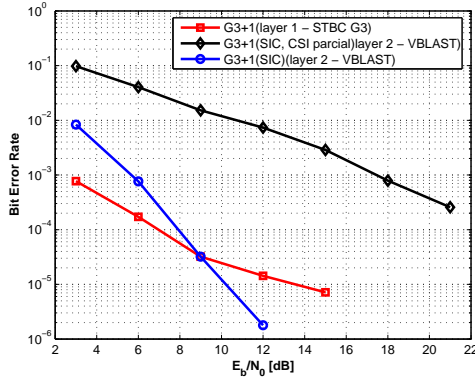

Fig. 8. Result per layer for the second possible solution: partial CSI at transmitter side.

2) *Partial CSI at Transmitter Side*: in this section we present the idea of the transmit antenna selection scheme for the HMTS based on a partial CSI at the transmitter. In this way, we propose a transmit antenna allocation scheme for the HMTS based on a partial CSI at the transmitter. The idea is, since the bottleneck is in the VBLAST layers, the receiver estimates all the CSI and with this information obtain the power of each subchannel in an ordered way. Thus, just the order of the subchannels power is feedback to the transmitter and in this way the best subchannels for the VBLAST layers are selected.

Let the channel matrix linking each receiver and transmitter antenna be represented in the following manner

$$H_{Rx} = \begin{bmatrix} h_{11} & h_{12} & h_{13} & h_{14} \\ h_{21} & h_{22} & h_{23} & h_{24} \\ \vdots & \vdots & \vdots & \vdots \\ h_{N1} & h_{N2} & h_{N3} & h_{N4} \end{bmatrix}. \quad (11)$$

In the transmitter point of view we can define also a channel matrix  $H_{Tx}$  that is related with the receiver through the relation

$$H_{Tx} = H_{Rx}^T. \quad (12)$$

This new matrix has dimension  $4 \times N$  and each line represent the links between each transmitter antenna and all the receiver ones

$$h_m = [h_{m1} \quad h_{m2} \quad \dots \quad h_{mN}], m = 1, \dots, M. \quad (13)$$

In this way the power of each transmitter link can be obtained as

$$P_{h_m} = (h_m h_m^H). \quad (14)$$

Therefore, we can sort the power of each transmitter in the crescent order in a such a way that the strongest links are considered to transmit VBLAST layers, and the others are left to transmit using the STBC scheme, that provide some protection.

An interesting point is that is not necessary that the transmitter knows all the CSI, but just the order of the more

powerful links. We denote this approach as partial CSI. Thus, in this consideration no large overhead is created, and just some bits could be used to carry this information to transmitter.

Figure 7 shows the performance of the whole receiver when the CSI is known in the transmitter side. With this information a huge gain is achieved, about 10 dB can be achieved in a BER of  $10^{-3}$  compared with the case where there is no antenna allocation. Figure 8 shows the same comparison per layer. We can see that regarding the partial CSI at the transmitter side a closer performance of the space-time coded layer can be achieved. Furthermore, a better results is achieved in high  $E_b/N_0$ .

## VI. CONCLUSIONS

In this work we evaluate the system performance of two possible solution for the bottleneck present in the HMTS G3+1. Clearly, both presents a possible solution, however, the first one considering the channel coding has the drawback of the amount of redundancy transmitted and this is a overhead leading to a no clever bandwidth utilization. On the other hand, the partial CSI at transmitter side outperforms the channel coding solution, and it requires a simple parameter to be estimated at receiver and just the order of the strengths of each subchannels need to be feedback to the transmitter.

As perspectives, we can highlight the comparison of the two techniques when there is spatial correlation in the receiver side. And also other MIMO channel models, e.g. non-quasi-static MIMO wireless channels.

## REFERENCES

- [1] W. C. Freitas Jr., A. L. F. de Almeida, F. R. P. Cavalcanti, J. C. M. Mota, R. L. de Lacerda Neto, "Performance of MIMO Antenna Systems with Hybrids of Transmit Diversity and Spatial Multiplexing Using Soft-Output Decoding," In: 11th International Conference on Telecommunications. 2004, Fortaleza. APPEARING IN Lecture Notes in Computer Science, Springer-Verlag Heidelberg, v. 3124 /, p. 28-37, 10 ago. 2004.
- [2] L. Zheng and D. Tse, "Diversity and Multiplexing: A Fundamental Tradeoff in Multiple Antenna Channels," *IEEE Transactions on Information Theory*, vol. 49, May 2003, pp. 1073-96.
- [3] G. J. Foschini, "Layered Space-Time Architecture for Wireless Communications in a Fading Environment when using Multiple Antennas", *Bell Labs Tech. J.*, v.1, n.2, 1996, pp.41-59.
- [4] V. Tarokh, H. Jafarkhani, and A. R. Calderbank, "Space-time Block Codes from Orthogonal Designs," *IEEE Transactions on Information Theory*, vol. 5, pp. 1456-1467, Jul 1999.
- [5] S. Alamouti, "A Simple Transmit Diversity Technique for Wireless Communications," *IEEE Journal of Selected Areas in Communications*, vol. 16, pp. 1451-1458, Oct 1998.
- [6] 3GPP TR 25.876, "TR 25.876 Multiple Input Multiple Output (MIMO) antennas in UTRA," v1.5.1, 2004-05.
- [7] E. Telatar, "Capacity of Multi-antenna Gaussian Channels," *Bell Labs Tech. J.*, June, 1995.
- [8] Branka Vucetic and Jinhong Yuan, "Space-Time Coding," *West Sussex, England ; Hoboken, NJ : Wiley, c2003. TK5102.92.V82*, 2003.
- [9] V. Tarokh V, A. Naguib, N. Seshadri, and A. R. Calderbank, "Space-time Codes for High Data Rate Wireless Communication: Performance Criteria In the Presence of Channel Estimation Errors, Mobility, and Multiple Paths," *IEEE Transactions on Communications*, Vol. 47: No. 2, pp. 199-207, Feb. 1999.